

# F600 class

COOLING TOWER



---

Specifications / Base

Base	4
Thermal Performance	5
Design Loading	5
Circulating Water Quality	6
Structure	6
Fan Deck and Fan Cylinders	7
Fill and Drift Eliminators	8
Mechanical Equipment	9
Hot Water Distribution System	10
Cell Partitions	11
Casing and Louvers	11
Access and Safety	12
Scope of Work	13

---

Specifications / Options

Premium Hardware Options	
Level 1 - Series 300 Stainless Steel	14
Level 2 - Type 316 Stainless Steel	15
Level 3 - Silicone Bronze	16
Driveshaft Material Options	
All Stainless Steel Driveshaft	17
Carbon Fiber Driveshaft / Stainless Steel Couplings	17
Access and Maintenance Options	
Vertical Ladder at End of Tower	18
Second Stairway at End of Tower	18
Cased Stairway	18
Mechanical Equipment Temporary Access Catwalk	18
Mechanical Equipment Permanent Access Catwalk	18
Endwall Derrick	19
Fan Cylinder View Port	19
Water Quality Options	
Basin Covers	19
DH Distribution Basin Covers	19
Piping System and Materials Options	
Manifold Piping	19
End Inlet Piping	20
Miscellaneous Options	
Longitudinal Cell Partitions	20
Heavy Louvers	20
Column Extensions	21
Control Options	
Control System	21
Vibration Limit Switch	22
Variable Speed Drive	22
Low Oil Switch	23
Fire Safety Options	
Fire-Retardant Fan Cylinders	23
Fire-Retardant Casing, Louvers and Corner Rolls	23



Marley F600 towers are field-erected, heavy duty, splash-fill, crossflow cooling towers designed to serve all normal cooling water systems—as well as those “dirty water” systems which would place the long term operation of a film-fill tower in jeopardy. Structural components are inert fiberglass composite pultrusions. They evolve from the crossflow concept of towers pioneered by Marley in 1938, and incorporate over 60 years of design advancements that our customers have found valuable. The Marley F600 represent the current state of the art in this cooling tower category.

This publication not only relates the language to use in describing an appropriate F600 cooling tower— but also defines why certain items and features are important enough to specify with the intention of insisting upon compliance by all bidders. The left hand column of all pages provides appropriate text for the various specification paragraphs, whereas the right hand column comments on the meaning of the subject matter and explains its value.

Pages 4 through 13 indicate those paragraphs that are descriptive of a cooling tower which will not only accomplish the specified thermal performance, but which will include normal operation, and maintenance-enhancing accessories and features. It will also incorporate those standard materials which testing and experience has proven to provide best results in normal operating conditions.

Pages 14 through 23 provide some paragraphs intended to add those features, components, and materials that will customize the tower to meet the user's requirements.

Space does not permit definition and explanation of all of the possible options that can be applied to the F600. SPX Cooling Technologies realizes that you, the purchaser, must be happy with the tower's characteristics, and we are prepared to provide—or provide for—any reasonable enhancement that you are willing to define and purchase.

Specifications	Specification Value
<p><b>1.0 Base:</b></p> <p><b>1.1</b> Furnish and install an induced-draft, cross-flow-type, field-erected, fiberglass-framed, splash-fill, industrial-duty cooling tower of ____ cell(s), situated as shown on the site plan. The limiting overall dimensions of the tower shall be ____ ft wide x ____ ft long x ____ ft high to the top of the fan cylinders. Total operating horsepower of the fans shall not exceed ____ hp.</p>	<p>■ This leadoff paragraph establishes the type, configuration, base material, and physical limitations of the cooling tower to be quoted. During the planning and layout stages of your project, you may have focused your attention on a cooling tower selection that fit your space allotment, and whose power usage was acceptable. Limitations on physical size and total operating horsepower avoid the introduction of unforeseen operational and site-related influences. Even further control of this problem will result if you specify the number of cells, and the maximum fan hp/cell.</p> <p>You are specifying a crossflow tower, which is a type noted—and often specified—for its accessibility, maintainability, and flexibility of operation. Open, gravity-flow distribution basins, adjustable valves, full-height fan plenums, and accessible components all combine to make the crossflow design very user friendly—and the value of these components is explained, where appropriate, throughout this specification.</p> <p>You are specifying a splash-fill tower. The normal air/water relationship in a crossflow tower lends itself to the best use of wide-spaced, non-clogging splash-type fill. The crossflow's natural affinity to splash fill is often the principal reason for it being specified.</p> <p>You are also specifying materials of construction which are impervious to the ills that beset towers constructed of more traditional materials. Life expectancy is not typically a characteristic of concern in this tower.</p> <p><b>Note: If it is your intention to evaluate offerings on the basis of first cost plus the cost of ownership and operation, please be clear on your inquiry documents regarding the parameters under consideration, as well as the value that you intend to place upon each of them. (i.e. dollars per hp; dollars per ft of pump head; dollars per sq ft of basin area; etc.) They WILL affect the sizing of the tower.</b></p>

Specifications	Specification Value
<p><b>2.0 Thermal Performance:</b></p> <p><b>2.1</b> The tower shall be capable of cooling _____ gpm of water from ____ °F to ____ °F at a design entering air wet-bulb temperature of ____ °F. The cooling tower manufacturer shall guarantee that the tower supplied will meet the specified performance conditions when the tower is installed according to plan. If, because of a suspected thermal performance deficiency, the owner chooses to conduct an on-site thermal performance test in the presence of the manufacturer, and under the supervision of a qualified, disinterested third party in accordance with CTI (Cooling Technology Institute) ATC-105 standards during the first full year of operation; and if the tower fails to perform within the limits of test tolerance; then the cooling tower manufacturer shall make alterations as it deems necessary to overcome indicated deficiency. Should alterations prove to be inadequate, the owner, at the cooling tower manufacturer's option, shall be compensated by either (or a combination of both) of the following: (a) Installation of additional cooling tower capacity; (b) A refund of a percentage of the contract price proportional to the deficiency as established.</p> <p><b>3.0 Design Loading:</b></p> <p><b>3.1</b> The tower and all its components shall be designed to withstand a wind load based on ASCE-7 and a seismic load based on UBC. As a minimum, a stability load of 2 1/2% shall be applied to the structure. For non-domestic jobs, a minimum design wind load of 30 psf shall be used. Fan decks and other work levels shall be designed for a uniform load of 60 psf, or a concentrated live load of 600 lb. Allowable deflection at 60 psf uniform load shall be 1/180 of span. Fill and fill supports shall be capable of withstanding a 40 psf live load. Guardrails shall be capable of withstanding a concentrated live load of at least 200 lb applied in any direction at any point along the top rail.</p>	<p>■ Your reason for purchasing a cooling tower is to obtain a continuing flow of cooled water as defined in the paragraph at left. If the tower that you purchase is incapable of performing as specified, then you will not have received full value for your investment.</p> <p>Bear in mind that the size—and cost—of a cooling tower varies directly with its true thermal capability. This paragraph is intended to protect you against either intentional or inadvertent undersizing of the tower by the manufacturer. Judging the level of performance of a cooling tower on critical processes is never easy, and the potential risk of a non-performing cooling tower usually causes the requirement for a mandatory acceptance test to be very desirable.</p> <p>Your contract with the successful bidder should establish the acceptable remedies for missed performance, which might include:</p> <ul style="list-style-type: none"> <li>▪ The addition of one or more cells of tower, as necessary, to bring the cooling tower to the specified level of performance. This is usually limited to the scope of work as defined in the specifications, which means that you (the owner) will have to pay for the additional basin, wiring, starters, piping, etc.</li> <li>▪ The reimbursement of a portion of the total contract price equal to the percentage deficiency in performance.</li> </ul> <p><b>Under no circumstances should you allow the manufacturer to repitch the fans to increase motor brake horsepower above that shown in the proposal. That creates additional operating costs that will continue for the life of the tower—and imposes no penalty on the manufacturer.</b></p> <p>■ Although very strong, molded FRP decking material is relatively flexible. For this reason, it is important to limit deflection at design load to no more than 1/180 of span. Otherwise, decking and working platforms would be much too springy for the appropriate and comfortable handling of equipment.</p> <p>The indicated design values are the minimum allowables under normal design standards. If your geographic location dictates higher wind load, seismic load, or deck loading values, please make the appropriate changes.</p>



**Specifications**

**Specification Value**

**4.0 Circulating Water Quality:**

4.1 It is anticipated that the circulating water will have the following characteristics:

pH range	_____ to _____
Chlorides (NaCl)	_____ ppm
Sulfate (SO <sub>4</sub> )	_____ ppm
Sodium Bic. (NaHCO <sub>3</sub> )	_____ ppm
Calcium (CaCO <sub>3</sub> )	_____ ppm
Oil or grease	_____ ppm
Silica (SiO <sub>2</sub> )	_____ ppm
Max water temperature	_____ °F
Total suspended solids	_____ ppm
Bacteria count	_____ cfu/ml
(Other)	_____

4.2 The specifications, as written, are intended to indicate those materials that will be capable of withstanding the above water quality in continuing service. They are to be regarded as minimum requirements. Where components peculiar to individual tower designs are not specified, the manufacturer shall take the above water quality into account in the selection of their materials of manufacture.

**5.0 Structure:**

5.1 Tower framework shall consist of structural shapes of pultruded fiberglass composites having a flame spread rate of 25 or less. Columns and diagonals shall be 3" x 3" or larger box-section, with a minimum 1/4" wall thickness. Columns shall be spaced on no greater than 8'-0" centers both longitudinally and transversely. Columns requiring anchorage shall be anchored to the concrete cold water basin by heavy gauge series 300 stainless steel anchor clips.

5.2 Except at hot water basin and fan deck support levels, longitudinal and transverse girts shall be 4" channel sections located on both sides of interior columns; and on the inside of all perimeter columns. Girts at the hot water basin and fan deck support levels shall typically be 6" channel sections. These members sizes may vary depending on tower loading. Girt lines shall be located on vertical centers not to exceed 6'-0".

■ For purposes of this specification, "normal" circulating water conditions are defined as follows:

- A pH level between 6.5 and 9.0.
- A chloride content below 750 ppm (NaCl) — or below 455 ppm (Cl -).
- A sulfate content (SO<sub>4</sub>) below 1200 ppm. (Sulfates can attack concrete, and contribute to scale.)
- A sodium bicarbonate (NaHCO<sub>3</sub>) content below 300 ppm.
- Calcium (CaCO<sub>3</sub>) below 800 ppm.
- Oil and/or grease negligible.
- Silica (SiO<sub>2</sub>) below 150 ppm.
- A maximum hot water temperature of 120°F.
- Total suspended solids (TSS) below 50 ppm.
- A bacteria count <10,000 cfu/ml.
- No significant contamination with unusual chemicals or foreign substances.

If your circulating water quality falls outside any of the parameters listed above, some changes in the materials specifications may be required, most of which are listed on pages 13 thru 15. Where there is any question in your mind, please provide Marley with an analysis of your makeup water, along with the number of concentrations you intend to permit in your circulating water. Better still, since the quality of the water in a cooling tower soon reflects the quality of the surrounding air, an analysis of the circulating water from another cooling tower on site, if one exists, might be very informative.

Except for those unusual operating situations where the circulating water may be so laden with suspended solids, algae, fatty acids, product fibers, active organisms reflected in BOD, and the like that plugging of the cooling tower fill is a probability, reasonable attention to the hardware materials and/or their coatings is all that is normally required. Please work with your Marley sales representative.

■ Where the tower's incoming hot water temperature consistently exceeds 120°F, the strength characteristics of the pultruded fiberglass may be reduced, particularly in the distribution area of the tower. Depending upon the size of the tower, and the resultant safety margins, some changes in member sizes or resins used may be required.



Marley has produced a number of *Marley Difference* publications having to do with both the science, and the art, of designing cooling towers. *Marley Difference "Item S-7"* of that series discusses diagonals, and explains the need to maintain a straight "line of action" throughout the diagonal.

Series 300 stainless hardware is appropriate for the "normal" water conditions defined on page 6. If your air or water quality dictates hardware of higher premium (i.e. type 316 stainless steel, silicon bronze, etc.), please see pages 14 through 17, and discuss your requirements with your Marley sales representative.

**Specifications**

**Specification Value**

**5.3** A tension/compression system of diagonal braces shall stiffen the structure and transfer wind and seismic loads to the basin anchor points. Diagonal connectors used to transmit forces through column lines shall be of 1/2" thick fiber reinforced polyester (FRP). Diagonals shall be anchored to the cold water basin using heavy gauge series 300 stainless steel anchor clips. The line of action through the diagonal to the point of anchorage shall be straight.

**5.4** All structural connections and splices shall be through-bolted using full shank 1/2" diameter, or larger, series 300 stainless steel machine bolts, nuts and washers. Glued structural connections will not be allowed.

**5.5** Critical framing joints shall be augmented with 1/2" I.D., heavy wall (schedule 40) structural sleeves of series 300 stainless steel or fiberglass pultrusion. Framing specific to those joints shall be factory-drilled to accept insertion of the sleeves. Bidders shall include with their quotation complete framework wind and/or seismic diagrams along with column operating and shutdown point loads for all models quoted, based upon the specified performance and design loadings.

**6.0 Fan Deck and Fan Cylinders:**

**6.1** The fan deck shall act as a working platform for maintenance personnel. It shall be pultruded fiberglass having a flame spread rating of 25 or less with a top surface at least 0.12" thick and shall have a slip resistant surface. Fan deck panels shall be supported by framing girts and shall interlock along the lengths of the panels to prevent differential deflections between panels. To minimize turbulence of airflow into the fan cylinder, fan deck protrusion into the fan cylinder opening shall not exceed 1".

**6.2** Fan cylinders shall be molded FRP, no less than 7'-0" high, with eased inlets to promote smooth airflow at blade tips. The operating plane of the fan shall be at a level above the fan deck of at least 15% of the overall fan diameter. Fan tip clearance shall not exceed 0.5% of the fan diameter. If velocity recovery fan cylinders are used, they shall have a maximum flare angle of 12°, with a maximum assumed velocity recovery of 75% of the difference in average velocity pressure. Each



The resin-rich surface veil applied to all molded or extruded FRP parts makes field-gluing inappropriate and structurally inadequate. Having no fiber content, this veil is the weakest area of the part, and must be properly removed to permit bonding to the fibrous structural layer. This is very difficult under field conditions and, coupled with the absence of any temperature and humidity control, makes field-glued joints not only ineffective, but potentially dangerous.



To have structurally designed their offerings, bidders will have had to develop the framework wind and/or seismic. Please require them.



■ Fiber reinforced polyester fan cylinders provide the close tip clearances and smooth airflow contour necessary for good fan performance. The inert, non-corroding nature of FRP assures that these characteristics will persist. *Marley Difference "Item A-1"* explains the need for the specification language indicated at left.

If fire-retardant FRP is required or preferred for fan cylinders, please add the words **"having a flame spread rate of 25 or less"** after "FRP".

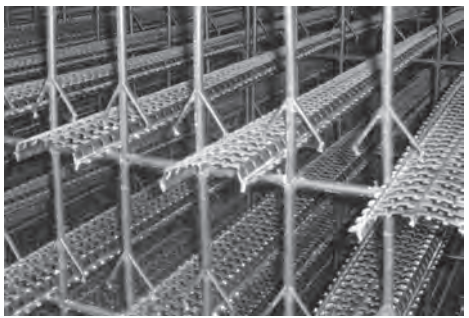

Specifications	Specification Value
fan cylinder segment shall be through-bolted to both the fan deck and a primary fan deck framing member. Anchorage by lag screws into the fan deck alone will not be permitted. Fan cylinder connection and anchorage hardware shall be series 300 stainless steel.	
<b>7.0 Fill and Drift Eliminators:</b>	
<b>7.1</b> Fill shall be splash-type, consisting of polyvinyl chloride splash bars hung in polypropylene grids installed in independent 4'-0" longitudinal bays and 6'-0" elevations. Splash bars shall be extruded PVC, cut to a length appropriate to fit within the bay with room for expansion. They shall be spaced on centers as necessary to achieve the required thermal performance. Each bay of splash bars shall be supported by two or more grids as necessary to prevent bar-sagging and resultant channeling of water.	<p>■ Splash-type fill has the longest history of successful use in the cooling tower industry. Its wide spacing discourages clogging, and its stout construction will withstand repeated cleaning of deposits associated with the circulating water quality.</p> <p>However, crossflow-type fill is very sensitive to the manner in which it is supported. Design water loadings can reach 20 gpm/sq ft and, unless supported on sufficiently close centers, the splash bars will begin to sag and allow the water to "channel". This reduces tower performance, and renders it unpredictable.</p>  <p>The effectiveness of the fill as a heat transfer medium varies with the size and shape of the splash bars, as well as their vertical and horizontal spacing density. The indicated minimum splash bar spacing is by no means abnormal, and it establishes a datum that assures the fill to be truly non-clogging, and cleanable.</p> <p>Because fills of different materials are usually shaped differently (molded, extruded, etc.), the material specified can also have an impact on its ability to perform and, therefore, have an impact on the size of the tower. Usually, fills of specific materials are specified because of unusual water quality or operating temperature, or perhaps the need to resist fire. Before writing the specification, please discuss the appropriate fill material and configuration with your Marley sales representative.</p>
<b>7.2</b> Drift eliminators shall be three-pass cellular, manufactured from a minimum of 17 mil thick PVC. Eliminators shall be manufactured and installed in packs no less than 6'-0" long. Packs shall nest together without air gaps, and shall be easily removable for cleaning and/or replacement. Eliminators shall be designed and manufactured specifically for crossflow cooling towers. The eliminator's final pass shall direct the airflow toward the fan. Maximum allowable drift shall not exceed 0.010% of the design water flow rate.	<p>Vertical blade-type eliminators, as well as misdirected cellular types cause much of the fan power to be wasted in turning the flow of air from horizontal to vertical for its exit through the fan cylinder. This power is, of course, not available for contribution to thermal performance. Refer to <i>Marley Difference "Item P-2"</i>. Drift rate varies with design water loading, air rate, drift eliminator depth, and density. The indicated rate of 0.010% is easily achievable without premium cost. If a lower rate is required, please discuss with your Marley sales representative.</p>



Specifications	Specification Value
<p><b>8.0 Mechanical Equipment:</b></p> <p><b>8.1</b> The primary air delivery system for each cell shall consist of an electric motor, an extended drive shaft, a geared speed reducer, a multi-blade propeller-type fan, and a rigid unitized support.</p> <p><b>8.2</b> Motors shall be _____-speed, single winding, variable torque, _____ hp maximum, TEFC, and specially insulated for cooling tower duty. Speed and electrical characteristics shall be _____ RPM, _____ phase, _____ hertz, _____ volts. If the load applied to the motors exceeds 90% of their nameplate rating, then they shall have a 1.15 service factor and the service factor beyond 1.0 shall not be considered available for load.</p> <p><b>8.3</b> Motors shall be located outside the fan cylinders and shall be connected to the speed reducers by tubular, extended, full floating, non-lubricated drive shafts. Drive shaft tubes and flanges shall be manufactured of type 304 stainless steel. Couplings shall be hot dip galvanized cast iron, joined to the drive shaft by flexible neoprene bushings and cadmium plated steel inserts. Connecting hardware shall be 300 stainless steel. Drive shaft assemblies shall be dynamically balanced at the factory at full motor speed. Two galvanized steel drive shaft guards anchored to the mechanical equipment support shall surround the drive shaft for containment in the event of failure.</p> <p><b>8.4</b> Speed reducers shall be right-angle type, utilizing helical and/or spiral bevel matched gear sets. Cases shall be epoxy coated, ASTM Class 20, gray cast iron. Bearings shall be tapered roller type. Gears and bearings shall be splash-lubricated in a bath of turbine type mineral oil, and units shall be capable of operating in either forward or reverse with equal facility. Speed reducers using external oil pumps will not be allowed. Speed reducers shall meet or exceed the requirements of CTI STD-111 and AGMA Std. 420.04, and service factor at applied horsepower shall not be less than 2.0. They shall be run-in under load and adjusted at the factory, and the interior surfaces coated with a rust-proofing oil prior to shipment.</p>	<ul style="list-style-type: none"> <li>■ Typical speed choices are “single” or “two”. Two-speed motors are worthy of your consideration because of the increased controllability they offer — and because of their significantly reduced annual power requirements.</li> <li>■ For 60 Hz power, single-speed design is 1800 RPM, and normal two-speed design is 1800/900 RPM.</li> <li>■ For 50 Hz power, single-speed design is 1500 RPM, and normal two-speed design is 1500/750 RPM.</li> </ul> <p>Change the motor specifications to indicate the characteristics you require. Dual winding, explosion proof, 1800/1200 RPM, space heaters, etc.</p> <ul style="list-style-type: none"> <li>■ The drive shaft turns at the motor speed and is, therefore, most sensitive to operational imbalance. Stainless steel manufacture assures that the drive shaft will not become unbalanced as a result of corrosion.</li> </ul> <p>The heavy nature of the castings from which the couplings are machined usually makes the hot dip galvanized couplings acceptable in all but the more corrosive atmospheres. See page 17 for optional “all stainless” and carbon fiber drive shafts.</p> <ul style="list-style-type: none"> <li>■ The Geareducer® is, essentially, the heart of your fan drive system. It must support the fan, rotate the fan at the appropriate speed, and maintain critical fan positioning within the fan cylinder—and it must perform these functions reliably through many long years of demanding use.</li> </ul> <div style="display: flex; align-items: flex-start;">  <div style="margin-left: 20px;"> <p>Requiring adherence to the standards specified helps to assure that level of dependability.</p> </div> </div>



Specifications	Specification Value
<p><b>8.5</b> Each cell shall be equipped with an external oil level gauge and gear reducer drain line, terminating at a sight-glass and plug located outside the fan cylinder near the motor.</p>	<ul style="list-style-type: none"> <li>■ The extended oil line to an external sight-glass provides a means of checking the level of oil in the Geareducer. It also permits periodic draining of the Geareducer at a convenient location.</li> </ul>
<p><b>8.6</b> Fans shall have a minimum of five GRE (glass reinforced epoxy) blades, with appropriate twist and taper to produce maximum airflow. All blades shall be fabricated with consistent moment weights to permit the change-out of individual blades without the need for total fan rebalance. Hubs shall be fabricated of hot dip galvanized steel and ductile cast iron, assembled with series 300 stainless steel hardware. Spoke-type hubs, if used, shall be equipped with an FRP hub cover to prevent recirculation of air at the plane of the fan. Hubs shall be statically balanced at the factory.</p>	<ul style="list-style-type: none"> <li>■ Many of the large fans used on cooling towers operate at tip speeds approaching 13,000 ft/min. When the blade tips encounter the occasional solid droplet of water that escapes the eliminators, erosion of the leading edge can occur on fans whose designs do not address this problem. This has, over time, contributed to some fan failures in the past.</li> </ul>
<p><b>8.7</b> The complete mechanical equipment assembly for each cell shall be supported by a rigid, unitized, torque-tube type support that prevents misalignment between the motor and the gear reducer. Support shall be heavy-wall tubular steel, to which heavy plate platforms for the motor and gear reducer have been welded, as well as structural outriggers to provide structural stability and transmit loads into the tower structure. The assembly shall be hot dip galvanized after fabrication.</p>	<p>Fans of the size used on large cooling towers are applied at speeds and horse-powers that generate considerable torque — and structural tubular steel resists this torque most effectively. The Marley torque-tube assures that all of the mechanical equipment remains aligned, and that the rotating fan is properly positioned within the fan cylinder. Hot dipping after fabrication assures that all steel surfaces will be heavily coated with zinc for long-term protection against corrosion.</p>
<p><b>9.0</b> <b>Hot Water Distribution System:</b></p>	<p>■ Open, gravity-flow distribution basins are a feature of crossflow type towers that adds to their reputation of being simple to operate and easy to maintain. These basins are out where they can be easily inspected—even maintained—while the tower is in operation. Spray systems of counterflow towers, sandwiched between the top of the fill and the drift eliminators, are comparatively awkward to access, and require tower shutdown for maintenance.</p>
<p><b>9.1</b> Two hot water distribution basins located above the banks of fill shall extend the full length of the tower. Basin floor shall pultruded fiberglass having a flame spread rating of 25 or less. Basin walls shall provide adequate freeboard at full design water flow. Basins shall deliver incoming hot water to the fill by gravity, through removable polypropylene metering orifice nozzles located in the floor of the basins on 1'-0" centers. Nozzles shall be easily accessed and cleaned.</p>	<p>This describes the "side inlet" method of piping the cooling tower. It requires you to provide a header at the base of the tower, along with separate risers for each cell. Using this method, you may conveniently valve off cells on an individual basis.</p>
<p><b>9.2</b> Water shall come to these basins via a system of separate inlet piping and valves for each cell of the tower. Individual flanged inlets shall be located outside the louvered face of the tower, above the elevation of the distribution basins, at or near the fan center line of each cell. Inlet piping shall deliver water to the distribution basins through heavy-duty flow-control valves located over the inlet-side and far-side basins, traversing the fan plenum as necessary to do so.</p>	<p>Other optional piping methods are available, as described on pages 19 and 20.</p> <p>In cold weather regions, you should also consider running a valved drain line from the riser to the cold water basin to drain the riser during shutdown in freezing weather.</p> <p>Bypasses, if used, should be designed only after thorough discussion with your Marley sales representative.</p>



**Specifications**

Inlet and crossover piping shall be reinforced thermosetting resin, beginning with flanges for connection to owner’s risers. Inlet and bolt circle dimensions shall conform to 150# flange specifications.

**9.3** Valves shall be right-angle, disc type, discharging water downward into covered, labyrinth-type splash-suppression boxes in the basins. Valve bodies, discs, operating handles, and locking bars shall be epoxy-coated, machined cast iron. Screw-type operating stems shall be Series 300 stainless steel. Valves shall be capable of flow-regulation to each cell and each distribution basin. They shall also be capable of shut-off to permit taking one or more basins or cells out of operation for a period of inspection or maintenance.

**10.0 Cell Partitions:**

**10.1** The tower shall be partitioned such that the fan of each cell can be operated and cycled independently of the remaining cells. Full-width, 8 oz/sq ft FRP panel partitions shall extend from casing to casing across the tower, and from the top of the fill upward to the underneath side of the fan deck floor.

**10.2** The hot water distribution basins shall include watertight partitions between cells to permit removing individual cells from service.

**11.0 Casing and Louvers:**

**11.1** The endwalls of the tower, as well as the elevated sidewalls of the fan deck, shall be cased with 8 oz /sq ft corrugated FRP panels attached to tower columns with stainless steel screw shank or ring shank fasteners and self-sealing washers. Panels shall be installed with corrugations horizontal, and shall be lapped to shed water inward to the tower. Vertical joints shall be lapped and sealed watertight. Casing ends at tower corners shall be covered with 12 oz/sq ft FRP 90° corner rolls.

**12.2** The entire height and length of the two air inlet faces of the tower shall be louvered with minimum 9 oz/sq ft corrugated FRP panels depending on icing potential and column spacing. Louvers shall be 4" pultruded chan-



**Specification Value**

The need to adjust—and readjust—water flow as necessary to accommodate on-line maintenance and other operational variations over the life of the tower, dictates that the flow-control valves be of heavy-duty construction.

- Multicell towers must have partitions between cells. Otherwise, air will be induced downward through an inoperative fan, bypassing the fill of the operating cell. Without these partitions, part-load or off-season operation of the tower would be completely unsatisfactory.

Maintenance requirements and/or variations in load often require the shutdown of individual cells. These partitions make this possible.

- If preferred, change casing thickness to 12 oz/sq ft.

Also, the casing, louvers and corner rolls can be manufactured in fire resistant or fire retardant formulation. Fire resistant provides a flame spread rate less than 75. Fire retardant provides a flame spread rate of 25 or less. If desired, please add either the words “fire resistant” or “fire retardant” before the designation “FRP” in paragraphs 12.1 and 12.2.



- External louvers must be considered mandatory on splash-fill towers. Water that naturally exits the fill on the outboard side will create a swamp outside the tower unless it is returned to the tower by a well-designed set of louvers. To be effective, however, the louvers must overlap each other—cover the full vertical face of the fill—and extend the full length of the tower.

Specifications	Specification Value
<p>nel arms attached to the louver columns, and supported at the top by polypropylene support bars. Louver columns shall be sloped to maintain louver position in close proximity to the fill for control of water splash, and for purposes of deicing. Louvers shall overlap each other vertically to retain water flow within the tower.</p>	
<p><b>12.0 Access and Safety:</b></p>	
<p><b>12.1</b> The tower shall be designed and equipped to provide comfortable, safe access to all components requiring routine inspection and maintenance.</p>	<p>■ The rigors of normal industrial cooling tower operation require that all vital areas of the tower be readily, easily, and safely accessed.</p> <p>Be extremely wary of those manufacturers who suggest that one of your access requirements is not really necessary. Their suggestion may be evidence that such access in their design is difficult—and may very well become a focus of significant cost to you in the future.</p>
<p><b>12.2</b> The fan deck of the tower shall be surrounded by sturdy 2" x 2" fiberglass guardrails and kneerails plus 4" high toeboards, all conforming to OSHA standards. The guardrail shall be 42" high. Both guardrails and kneerails shall be through-bolted to 3" x 3" columns on 6' centers longitudinally and transversely. The toeboards shall be fastened to the guardrail posts and fan deck with self drilling/self tapping screws.</p>	
<p><b>12.3</b> Each cell of the tower shall be equipped with vertical fiberglass ladders extending downward from the fan deck level to a walkway above the waterline in the hot water distribution basins. Walkways shall extend out to the splash box cover and flow-control valve.</p>	<p>■ Although the caged ladder at the other end of towers exceeding 200'-0" in length is not an OSHA requirement, it is recommended by SPX Cooling Technologies for reasons of personnel safety.</p>
<p><b>12.4</b> One endwall of the tower shall be equipped with a structural fiberglass stairway rising from the level of the cold water basin curb to the fan deck. Stairs shall be 30" wide with a slope of 41.5° and have an 8" rise and 9" run. Treads shall have a nonskid surface. Landings shall occur at 6'-0" elevations. Handrails and kneerails shall be 2" x 2", through-bolted to 3" x 3" stairway posts. All stairway bolts and fasteners shall be series 300 stainless steel. If the tower length exceeds 200'-0", a vertical steel ladder with safety cage per OSHA recommendations shall be provided at the other end of the tower. The ladder shall provide access from the cold water basin curb to the fan deck.</p>	<p>■ Stairways are also available at both ends of the tower and cased for snow and ice protection. See page 18.</p>

Specifications	Specification Value
<p><b>12.5</b> There shall be a 33" wide by 61" high molded FRP access door in each endwall of the tower at the cold water basin curb level. A 24" wide treated FRP walkway shall extend the full length of the tower at that level. Hinged doors shall also be provided in each partition between cells. If the floor of the cold water basin is 4'-0" or more below the walkway, the walkway shall include guardrails and kneerails. Toeboards shall also be provided.</p>	<ul style="list-style-type: none"> <li>■ The access doors on other towers may be unreasonably small. Specifying the size of the door will cause those bidders to take exception, alerting you to a potential maintenance headache.</li> </ul>
<p><b>12.6</b> Fan cylinders shall have removable segments of sufficient size to allow removal of all mechanical equipment components, and shall have a coupling guard, conforming to OSHA standards, to shroud that portion of the drive shaft that extends outside the fan cylinder.</p>	
<p><b>14.0 Scope of Work:</b></p>	
<p><b>14.1</b> The cooling tower manufacturer shall be responsible for the design, fabrication, and delivery of materials to the project site, and for the erection of the tower over a concrete basin and foundation. Cooling tower manufacturer will also supply anchor bolts. The concrete basin and foundation shall have been designed and installed by others, based upon certified loads and dimensions provided by the cooling tower manufacturer. Unless otherwise specified, all external piping, headers, risers, valves, pumps, sumps and screens, controls, electrical wiring, fire protection, lightning protection, and water treatment equipment will be outside the tower manufacturer's scope of work.</p>	<ul style="list-style-type: none"> <li>■ Please be clear in your specifications and inquiry documents regarding the full scope of work expected. That will help assure that your bid comparisons will be made on as equal a basis as possible—and will help to avoid any misunderstandings during the execution and implementation of the contract.</li> </ul>





Specifications	Specification Value
<p><b>Premium Hardware Options</b></p> <p><b>Level 1 - Series 300 Stainless Steel</b></p>	
<p><u>5.1</u> <i>Change the last sentence to read:</i> Columns requiring anchorage shall be anchored to the concrete cold water basin by Series 300 stainless steel anchor castings or weldments.</p> <p><u>5.3</u> <i>Change the fifth sentence to read:</i> Diagonals shall be anchored to the cold water basin using FRP diagonal connectors and Series 300 stainless steel anchor castings or weldments.</p> <p><u>8.3</u> <i>For an all stainless steel drive shaft change the third sentence to read:</i> Couplings shall be cast 304 stainless steel, joined to the drive shaft by flexible neoprene bushings and type 302 stainless steel inserts.</p> <p><i>Also, change the last sentence to read:</i> Two triple-epoxy-coated, galvanized steel drive shaft guards anchored to the mechanical equipment support shall surround the drive shaft for containment in the event of failure.</p> <p><i>For a carbon fiber drive shaft with stainless steel couplings, replace entire paragraph 9.3 with the description found on pages 19 and 20.</i></p> <p><u>8.6</u> <i>Add the following sentence at the end of the paragraph:</i> Galvanized steel components shall be epoxy-coated after galvanizing to a dry film thickness of 12 mils (.012").</p> <p><u>8.7</u> <i>Change last sentence to read:</i> The assembly shall be hot dip galvanized after fabrication, and epoxy-coated after galvanizing to a dry film thickness of 12 mils (.012").</p>	<p>■ All of the material changes listed under Level 1 are recommended where chlorides are below 1500 PPM (NaCl) or below 910 PPM (Cl<sup>-</sup>) but acidity is less than pH 6.5—or in the presence of H<sub>2</sub>S.</p> <p>The materials of construction indicated in the base specification are entirely suitable for the "normal" water conditions defined on page 6. If your water quality is typified by the conditions indicated in the description above, all of the changes indicated may be required. However, many of the components mentioned are outside intimate contact with the circulating water stream and, therefore, may not require specification revision. Bolts, nuts and washers, of course, are Series 300 stainless steel as standard.</p> <p>Also, several other water chemistries can occur that may or may not necessitate changes in materials of construction and/or operating procedures. Prior to finalizing the tower selection and specification, we ask that you provide us with your best analysis of what your circulating water quality and chemistry will be.</p> <p>The value of the specification revisions is, of course, that they help assure you will have achieved maximum longevity from your cooling tower in its anticipated operating environment.</p>

Specifications	Specification Value
<p><b>Level 2 - Type 316 Stainless Steel</b></p>	
<p><u>5.1</u> <i>Change the last sentence to read:</i> Columns requiring anchorage shall be anchored to the concrete cold water basin by type 316 stainless steel anchor castings or weldments.</p>	<p>■ All of the material changes listed under Level 2 are recommended where chlorides are between 1500 PPM and 4000 PPM (NaCl) or between 910 PPM and 2425 PPM (Cl -).</p> <p>The materials of construction indicated in the base specification are entirely suitable for the “normal” water conditions defined on page 6. If your water quality is typified by the conditions indicated in the description above, all of the changes indicated may be required. However, many of the components mentioned are outside intimate contact with the circulating water stream and, therefore, may not require specification revision.</p> <p>Also, several other water chemistries can occur that may or may not necessitate changes in materials of construction and/or operating procedures. Prior to finalizing the tower selection and specification, we ask that you provide us with your best analysis of what your circulating water quality and chemistry will be.</p> <p>The value of the specification revisions is, of course, that they help assure you will have achieved maximum longevity from your cooling tower in its anticipated operating environment.</p>
<p><u>5.3</u> <i>Change the second sentence to read:</i> Diagonal connectors shall be of fiber reinforced polyester (FRP), or type 316 stainless steel.</p> <p><i>Also, change the fifth sentence to read:</i> Diagonals shall be anchored to the cold water basin using FRP diagonal connectors and type 316 stainless steel anchor castings or weldments.</p>	
<p><u>5.5</u> <i>Change the paragraph to read:</i> All structural connections and splices shall be through-bolted using full shank 1/2" diameter, or larger, type 316 stainless steel machine bolts, nuts and washers.</p>	
<p><u>6.2</u> <i>Change the last sentence to read:</i> Fan cylinder connection and anchorage hardware shall be type 316 stainless steel.</p>	
<p><u>9.3</u> <i>For an all stainless steel drive shaft change the third sentence to read:</i> Couplings shall be cast 316 stainless steel, joined to the drive shaft by flexible neoprene bushings and type 302 stainless steel inserts.</p> <p><i>Also, change the last sentence to read:</i> Two triple-epoxy-coated, galvanized steel drive shaft guards anchored to the mechanical equipment support shall surround the drive shaft for containment in the event of failure.</p> <p><i>For a carbon fiber drive shaft with stainless steel couplings, replace entire paragraph 9.3 with the description found on pages 19 and 20.</i></p>	
<p><u>9.6</u> <i>Add the following sentence at the end of the paragraph:</i> Galvanized steel components shall be epoxy-coated after galvanizing to a dry film thickness of 12 mils (.012").</p>	
<p><u>9.7</u> <i>Change last sentence to read:</i> The assembly shall be hot dip galvanized after fabrication, and epoxy-coated after galvanizing to a dry film thickness of 12 mils (.012").</p>	

Specifications	Specification Value
<p><b>Level 3 - Silicone Bronze</b></p>	
<p><u>5.1</u> <i>Change the last sentence to read:</i> Columns requiring anchorage shall be anchored to the concrete cold water basin by heavy gauge silicon bronze anchor clips.</p>	<p>■ <b>All of the material changes listed under Level 3 are recommended where chlorides are above 4000 PPM (NaCl) or above 2425 PPM (Cl -) and where neither H<sub>2</sub>S nor ammonia are present.</b></p> <p>The materials of construction indicated in the base specification are entirely suitable for the “normal” water conditions defined on page 6. If your water quality is typified by the conditions indicated in the description at left, all of the changes indicated may be required. However, many of the components mentioned are outside intimate contact with the circulating water stream and, therefore, may not require specification revision.</p> <p><b>Silicon bronze, while very resistant to corrosion in a chloride environment, is subject to erosion in high-flow areas. Therefore, plastic cups, designed for this service, are used to prevent direct water impingement on the hardware.</b></p> <p>Several other water chemistries can occur that may or may not necessitate changes in materials of construction and/or operating procedures. Prior to finalizing the tower selection and specification, we ask that you provide us with your best analysis of what your circulating water quality and chemistry will be.</p> <p>The value of the specification revision is, of course, that they help assure you will have achieved maximum longevity from your cooling tower in its anticipated operating environment.</p>
<p><u>5.3</u> <i>Change the second sentence to read:</i> Diagonal connectors shall be of fiber reinforced polyester (FRP), or silicon bronze.</p> <p><i>Also, change the fifth sentence to read:</i> Diagonals shall be anchored to the cold water basin using FRP diagonal connectors and red brass anchor castings.</p>	
<p><u>5.5</u> <i>Change the paragraph to read:</i> All structural connections and splices shall be through-bolted using full shank 1/2" diameter, or larger, silicon bronze machine bolts, nuts and washers. Exposed bolt heads, threads and nuts shall be covered with plastic cups to prevent water impact erosion.</p>	
<p><u>6.2</u> <i>Change the last sentence to read:</i> Fan cylinder connection hardware shall be 316 stainless steel.</p>	
<p><u>8.3</u> <i>For an all stainless steel drive shaft change the third sentence to read:</i> Couplings shall be cast 316 stainless steel, joined to the drive shaft by flexible neoprene bushings and type 302 stainless steel inserts.</p> <p><i>Also, change the last sentence to read:</i> Two triple-epoxy-coated, galvanized steel drive shaft guards anchored to the mechanical equipment support shall surround the drive shaft for containment in the event of failure.</p> <p><i>For a carbon fiber drive shaft with stainless steel couplings, replace the entire paragraph 9.3 with the description found on pages 19 and 20.</i></p>	
<p><u>8.6</u> <i>Add the following sentence at the end of the paragraph:</i> Galvanized steel components shall be epoxy-coated after galvanizing to a dry film thickness of 12 mils (.012").</p>	
<p><u>8.7</u> <i>Change last sentence to read:</i> The assembly shall be hot dip galvanized after fabrication, and epoxy-coated after galvanizing to a dry film thickness of 12 mils (.012").</p>	

Specifications	Specification Value
<p><b><u>Driveshaft Material Options</u></b></p>	
<p><b>All Stainless Steel Driveshaft:</b></p>	<ul style="list-style-type: none"> <li>■ Normal HDG cast iron couplings may form blush rust over time. Where that is unwanted, or where abnormally high corrosion levels are anticipated, specify this all stainless steel driveshaft.</li> </ul>
<p><u>8.3</u> <i>Replace the third sentence with the following:</i> Couplings shall be cast 316 stainless, joined to the drive shaft by flexible neoprene bushings and type 302 stainless steel inserts.</p>	
<p><b>Carbon Fiber Driveshaft / Stainless Steel Couplings:</b></p>	<ul style="list-style-type: none"> <li>■ Carbon fiber drive shafts are preferred by many customers on the strength of their ability to remain dimensionally unaffected by long stationary periods in direct sunlight. Steel drive shafts may go through temporary unbalance in those circumstances.</li> </ul>
<p><u>8.3</u> <i>Replace the paragraph as follows:</i> Motors shall be located outside the fan cylinders and shall be connected to the speed reducers by tubular, extended, full floating, non-lubricated drive shafts. Drive shaft tubes shall be carbon fiber/glass/epoxy composite. Flanges shall be manufactured of type 316 stainless steel, attached to the tube by type 316 stainless steel compression rings. Couplings shall be cast 316 stainless, joined to the drive shaft by flexible neoprene bushings and type 316 stainless steel inserts. Connecting hardware shall be 316 stainless steel. Drive shaft assemblies shall be dynamically balanced at the factory at full motor speed. Two epoxy-coated hot dip galvanized steel drive shaft guards anchored to the mechanical equipment support shall surround the drive shaft for containment in the event of failure.</p>	<p>Normal HDG cast iron couplings may form blush rust over time. Where that is unwanted, or where abnormally high corrosion levels are anticipated, specify this drive shaft with stainless steel couplings.</p> <p>Use where chloride levels in the circulating water and drift may exceed 1500 ppm, as NaCl.</p>

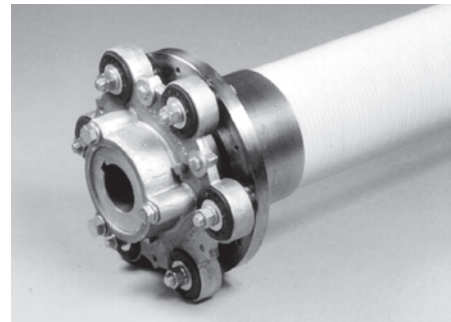

Specifications	Specification Value
<p><b>Access and Maintenance Options</b></p>	
<p><b>Vertical Ladder at End of Tower:</b></p>	
<p><u>12.4</u> <i>Delete the words: "if the tower length exceeds 200'-0" from the end of the sixth sentence.</i></p>	<ul style="list-style-type: none"> <li>■ These are sometimes referred to as "escape" ladders. They are a ready means of egress in case of emergency. If you want this ladder on your tower, regardless of length, please make the change indicated at left.</li> </ul>
<p><b>Second Stairway at End of Tower:</b></p>	
<p><u>12.4</u> <i>Change the first sentence to read as follows: Both endwalls of the tower shall be equipped with fiberglass stairways rising from the level of the cold water basin curb to the fan deck.</i></p>	<ul style="list-style-type: none"> <li>■ On long towers, a second stairway is a very desirable option for your maintenance people.</li> </ul>
<p><b>Cased Stairway:</b></p>	
<p><u>12.4</u> <i>Add the following to this paragraph: The stairway shall be roofed and cased with casing material to keep out snow and sleet. Roof support headroom shall be 7'-0" above top stairway landing. Latched doors shall be provided at the entrance and exit of the stairway. The door at the fan deck elevation shall open inward to prevent snow and ice build-up from rendering the door inoperable. Stairway side casings shall be translucent for visibility.</i></p>	<ul style="list-style-type: none"> <li>■ As the specification wording implies, the cased stairway is of great benefit in those geographic regions where heavy snowfalls are the norm.</li> </ul>
<p><b>Mechanical Equipment Temporary Access Catwalk:</b></p>	
<p><u>12.6</u> <i>Add the following sentence to this paragraph: Provide a 24" wide portable expanded aluminum catwalk, complete with handrail and kneerail, that will extend from the fan cylinder access way to the fan hub/gear reducer/drive shaft region.</i></p>	<ul style="list-style-type: none"> <li>■ This catwalk spans girt lines and provides short-term access to the mechanical equipment. It precludes the need to provide temporary planking, but does not obviate the need for temporary decking for major maintenance.</li> </ul>
<p><b>Mechanical Equipment Permanent Access Catwalk:</b></p>	
<p><u>12.6</u> <i>Add the following to this paragraph: Each cell shall be equipped with a 24" wide, permanently-installed walkway extending from the fan cylinder access way to a work platform at the fan hub/gear reducer/ drive shaft region. Catwalk and work platform shall be FRP, and shall be equipped with either FRP or galvanized steel guardrails and kneerails.</i></p>	<ul style="list-style-type: none"> <li>■ This system avoids the need to install the temporary catwalk every time you need to perform major maintenance. It also provides a substantial work platform, without which you will have to put down temporary decking. Please check with your Marley sales representative to determine what, if any, effect this permanent fixture in the tower airstream will have on tower performance or operating horsepower.</li> </ul>



**Specifications**

**Endwall Derrick:**

12.7 *Add the following after this paragraph:* A permanent galvanized steel derrick shall be provided at the end of the fan deck to facilitate movement of equipment between the fan deck level and grade. Derrick shall be of a capacity sufficient to handle the motors or the gear reducers. Power, rigging, and cables will be provided by the Owner.

**Fan Cylinder View Port:**

6.2 *Add the following sentence to this paragraph:* Each fan cylinder shall include a 6" diameter, screened view port with a removable Plexiglas window.

**Water Quality Options**

**Distribution Basin Covers:**

9.1 *Add the following sentence to the end of the paragraph:* Basins shall be covered with removable FRP Panels.

**DH Distribution Basin Covers:**

10.1 *Add the following sentence to the end of the paragraph:* Distribution basins and piping shall be enclosed with a sloping roof covered structure. The structure shall be enclosed with 8-ounce FRP corrugated casing material. Removable panels shall be provided to allow access.

**Piping System Options**

**Manifold Piping:**

10.2 *Replace this paragraph with the following:* Water shall come to these basins via a formed RTR manifold header supported above one distribution basin and extending from the tower endwall to the approximate center of the last cell. Inlet piping shall deliver water to the distribution basins of each cell through heavy-duty flow-control valves located over the inlet-side and far-side basins, traversing the plenum as necessary to do so. Inlet-side valves shall be flanged directly to the manifold header. Far-side valves shall be at the end of RTR crossover pipes that traverse the plenum. The crossover pipes shall be connected to the header with a flanged connection. The



**Specification Value**

■ Normally, the fan deck level at the end of the tower is readily accessible by a small crane or "cherry picker", making this derrick unnecessary.

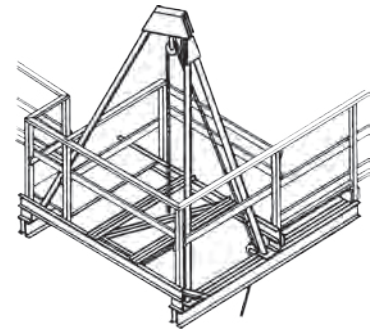

■ Allows on-line viewing of fan operation.

■ In wooded or heavily industrialized areas, these covers can keep leaves and debris from clogging up the water distribution system. They also serve to retard the growth of algae by shielding the incoming hot water from direct sunlight.

■ DH distribution basin covers provide generous head room for maintenance at the flow-control valves. The horizontal open area along the fan deck level allows natural light and ventilation within the enclosure. This durable low-maintenance structure is erected of pultruded fiberglass enclosed with 8-ounce corrugated FRP.

■ Manifold piping is useful where the total water flow does not exceed 107,000 gpm, and the gpm/cell does not exceed 20,000 gpm. It requires that you bring up a riser at the tower endwall, elbowing into the manifold header above the water distribution basin.

Specifications	Specification Value
<p>manifold header shall start with a _____" diameter inlet flange approximately 2'-0" outside the tower endwall, for connection to the owner's riser pipe. Inlet flange and bolt circle dimensions shall conform to 150# flange specifications. Header shall diminish in diameter as flow reduces after each cell, to limit flow velocity to no more than 10 fps. Header joints shall be of the bell and spigot type to accommodate thermal expansion.</p> <p><b>End Inlet Piping:</b></p> <p><u>10.1</u> <i>Replace this paragraph with the following:</i> Water shall come to these basins via formed RTR pipes supported one above each distribution basin and extending from the tower endwall to the approximate center of the last cell. Inlet piping shall deliver water to the distribution basins of each cell through heavy-duty flow-control valves flanged directly to the pipe. Each inlet pipe shall start with a _____" diameter, inlet flange approximately 2'-0" outside the tower endwall, for connection to the owner's riser pipe. Inlet flange and bolt circle dimensions shall conform to 150# flange specifications. Pipe diameter shall diminish as flow reduces after each cell, to limit flow velocity to no more than 10 fps. Pipe joints shall be of the bell and spigot type to accommodate thermal expansion.</p> <p><b>Miscellaneous Options</b></p> <p><b>Longitudinal Cell Partitions:</b></p> <p><u>10.1</u> <i>Add the following at the end of this paragraph:</i> A similar full-height longitudinal partition shall be provided in the internal area between banks of fill to reduce windage loss of water out of the louvered face. This partition shall be adjacent to the tower's internal longitudinal walkway, and there shall be an access opening through the partition in each cell.</p> <p><b>Heavy Louvers:</b></p> <p><u>11.2</u> <i>Change this paragraph to read:</i> The entire height and length of the two air inlet faces of the tower shall be louvered 16 oz/sq ft corrugated FRP panels. Louvers shall be 4" pultruded channel arms attached to the louver columns, and supported at the top by</p>	<ul style="list-style-type: none"> <li>■ End inlet piping is useful where the total water flow does not exceed 214,000 gpm. It requires that you bring up two risers at the tower endwall, each elbowing into the pipes above the water distribution basins.</li> </ul> <p>Although not mentioned herein, even larger flow volumes can be handled by utilizing Double End Inlets, where four of your risers would serve two of the tower manufacturer's pipes over each distribution basin. Please discuss this—or any other piping scheme—with your Marley sales representative.</p> <ul style="list-style-type: none"> <li>■ The louvered faces of crossflow towers can present large frontal areas to the wind. If the velocity of the wind is sufficiently high—over 20 mph, as a rule of thumb—the residual velocity exiting the downwind face may carry a portion of the circulating water with it. Over time, this may create an unsightly area on the lee side of the tower. This longitudinal partition acts as a windbreak to prevent blow-thru.</li> <li>■ Heavy louvers are designed to withstand normal snow loads, as well as those significant ice loads that can develop as a result of upset operation of the tower in freezing weather. The ice retainer bar helps to prevent dislodged chunks of ice from crashing down through the outboard sections of the fill.</li> </ul> <p>Download <i>Marley Technical Report H-003 "Operating Cooling Towers in Freezing Weather"</i> at <a href="http://spxcooling.com">spxcooling.com</a>.</p>

Specifications	Specification Value
<p>polypropylene support bars. Louver columns shall be sloped to maintain louver position in close proximity to the fill for control of water splash, and for purposes of deicing. Louvers shall overlap each other vertically to retain water flow within the tower.</p> <p><b>Column Extensions:</b></p> <p><u>5.1</u> <i>Change second sentence to read:</i> Interior columns shall be of a length that will accommodate a maximum cold water basin depth of _____ below the basin curb.</p> <p><b>Control Options</b></p> <p><b>Control System:</b></p> <p><u>8.8</u> <i>Add the following paragraph in the Mechanical Equipment section:</i> Each cell of the cooling tower shall be equipped with a UL listed control system in a NEMA 3R or 4X outdoor enclosure capable of controlling single-speed or two-speed motors as required, and designed specifically for cooling tower applications. The panel shall include a main fused disconnect with an external operating handle, lockable in the off position for safety. Across-the-line magnetic starters or solid state soft-start starters as required shall be controlled with a thermostat or solid state temperature controller. Door mounted selector switches shall be provided to enable automatic or manual control and wired for 120VAC control. Control circuit to be wired out to terminal blocks for field connection to a remote vibration switch and for access to extra 120VAC 50VA control power, overload trip alarms and remote temperature control devices. The temperature controller shall be adjustable for the required cold water temperature. If a thermostat controller is used, it shall be mounted on the side of the tower with the temperature sensing bulb installed in the cold water basin using a suspension mounting bracket. If a solid state temperature controller is used, the controller will be door mounted on the control panel. The temperature controller displays two temperatures—one for outgoing water and the other for set point. Water temperature input shall be obtained using a three-wire RTD with dry well in the outlet water piping and wired back to the solid state temperature controller in the control panel.</p>	<p>The louvers described in para. 11.2 are appropriate for towers intended for operation during warm seasons only, or for those installed where winter temperatures are moderate.</p> <ul style="list-style-type: none"> <li>■ This allows basins deeper than 5'-4" without the need to pour concrete piers for the support of a myriad of interior columns. Discuss the depth you need with your Marley sales representative.</li> <li>■ If it is your opinion that the control system for the cooling tower should be part of the tower manufacturer's responsibility, we are in wholehearted agreement with you. Who better to determine the most efficient mode and manner of a tower's operation—and to apply a system most compatible with it—than the designer and manufacturer of the cooling tower?</li> </ul>

### Specifications

#### Vibration Limit Switch:

**8.7** *Add the following paragraph in the Mechanical Equipment section:* A single-pole, double-throw vibration limit switch in a NEMA 4 housing shall be installed on the mechanical equipment support for wiring into the owner's control panel. The purpose of this switch will be to interrupt power to the motor in the event of excessive vibration. It shall be adjustable for sensitivity, and shall require manual reset.

#### Variable Speed Drive:

**8.8** *Add the following paragraphs in the Mechanical Equipment Section:* For fan control a complete UL listed variable speed drive system in a NEMA 12 indoor or NEMA 3R outdoor enclosure shall be provided. The VFD shall use PWM technology with IGBT switching. VFD output switching signal shall be programmed as not to cause mechanical vibration issues with back lash in gearbox teeth or vibration issues associated with long drive shafts. VFD shall be programmed for variable torque application. The VFD shall catch a fan spinning in the forward or reverse direction without tripping. VFD panel construction shall include a main disconnect with short circuit and thermal overload protection with external operating handle, lockable in the off position for lock-out tag-out safety procedures. A service switch directly ahead of the VFD shall be provided for voltage isolation during VFD maintenance. An integrated full voltage non-reversing bypass starter shall be furnished allowing fan motor operation if VFD has failed. In the event of a system fault the VFD program logic shall evaluate type of fault determining if safe to automatically transfer fan motor to the bypass starter. Automatic bypass with an earth ground condition shall not be allowed. Once in bypass mode the internal controls will continue to monitor cold-water temperature and cycle the fan motor on and off maintaining cold-water set point temperature. The drive system shall be designed and operated as a stand-alone system without the need for a BMS system. Operator controls shall be mounted on the front of the enclosure and shall consist of Start and Stop control, Bypass/VFD selector switch, Auto/Manual selector switch, Manual speed control, and solid-state temperature controller. An emergency bypass starter

### Specification Value

- Unless specified otherwise, a Marley M-5 vibration switch will be provided. The requirement for manual reset assures that the tower will be visited to determine the cause of excessive vibration.



- Marley VFD drive systems are designed to combine absolute temperature control with ideal energy management. The cooling tower user selects a cold water temperature and the drive system will vary the fan speed to maintain that temperature. Precise temperature control is accomplished with far less stress to the mechanical equipment components. The improved energy management provides fast payback. Indeed, many utilities offer generous rebates for users having installed VFD drives.

*Motors operated on a VFD shall carry a service factor of 1.0. When operating on a VFD, the drive parameters should be programmed to limit the current to motor nameplate hp. Adjust the Motor specification accordingly.*







# F600 class cooling tower

## SPECIFICATIONS

**SPX COOLING TECHNOLOGIES, INC.**

7401 WEST 129 STREET

OVERLAND PARK, KANSAS 66213 USA

P: 913 664 7400

F: 913 664 7439

[spxcooling@spx.com](mailto:spxcooling@spx.com)

[spxcooling.com](http://spxcooling.com)

In the interest of technological progress, all products are subject to design and/or material change without notice

ISSUED 03/2015 SPEC-F600-15

COPYRIGHT © 2015 SPX Corporation